

VENTS Quiet-Style



Intellectual axial low-noise and energy-saving fan for exhaust ventilation with air capacity up to 90 m³/h

Applications

- Innovative exhaust fan with stylish design for new comfort level in shower rooms, bathrooms, kitchens and other residential premises.
- Maximum air capacity combined with low noise level provide the ideal microclimate.
- Mounting into ventilation shafts or connection to Ø 100 mm.

Design

- Casing and impeller made of high-quality and durable UV-resistant plastic.
- Specially designed impeller aerodynamic profile provides high air capacity and low noise.
- The compact design enables wall and ceiling mounting.
- The shortened spigot for mounting into a ventilation shaft or connection to Ø 100 mm air ducts.
- The fan is equipped with a specially designed back valve to prevent back flow and heat losses during the fan standby.
- The fan exhaust spigot incorporates specially designed air rectifiers to reduce air turbulence, increase air pressure and lower noise level.
- High ingress protection rating ensures makes the fan the ideal solution for ventilation of a bathroom. The electronic components are protected with tight covers.

Motor

- Low energy demand 7.5 W due to new high-efficient motor.
- Maintenance-free bearings contain enough grease for 40 000 hrs non-stop operation.

- Motor on special anti-vibration dampers for vibration absorbing and silent operation.
- Motor equipped with overheating protection.

Modifications and Options



Quiet-Style T - off-delay timer modification with operating time from 2 to 30 min.



Quiet-Style TH - off-delay timer modification with the operating time from 2 to 30 min and humidity sensor with threshold from 60 to 90%.



Quiet-Style V - pull-cord switch modification.



Quiet-Style VT - modification with pull-cord switch and off-delay timer with operating time from 2 to 30 min.



Quiet-Style VTH - modification with pull-cord switch, off-delay timer with operating time from 2 to 30 min and humidity sensor with threshold from 60 to 90%.



Quiet-Style TP - modification with off-delay timer with operating time from 2 to 30 min and motion sensor; reach distance up to 4 m, viewing angle up to 100°.

Control

Manual control

- Manual control with a room light switch. The switch is not included into delivery set.
- The fans controlled by the built-in pull cord switch **V**. Not applied in case of ceiling mounting.
- Speed control is possible through a thyristor speed controller, see Electrical Accessories. Several fans may connected to the same controller. Speed controllers can not be connected to the fans with T, TH, VT, VTH modification.

Automatic control:

- By the electronic control unit **BU-1-60** (see Electrical Accessories). The control unit is supplied separately.
- By the timer **T** (the built-in run-out timer enables the fan operation within 2 to 30 minutes after the fan switching off).
- By the humidity sensor and timer **TH** (if the humidity level in the room exceeds the sensor threshold within 60-90% the fan switches automatically on and operates until the humidity level drops to the standard level, after that the fan continues operating within the set time period and shuts down).

Mounting features

- Installation directly inside a ventilation shaft.
- Flexible air ducts may be used in case of remote location of the ventilation shaft. Connection of the air duct to the exhaust flange with a clamp.
- Wall mounting with screws.
- Suitable for ceiling mounting.

Technical data

Model	Voltage [V] at 50 Hz	Power Consumption [W]	Current [A]	Maximum air capacity [m ³ /h]	Sound Pressure Level at 3 m [dB(A)]	Weight, kg	IP
VENTS 100 Quiet-Style	230	7,5	0,05	90	26	0,66	IP 45

Aerodynamic characteristics

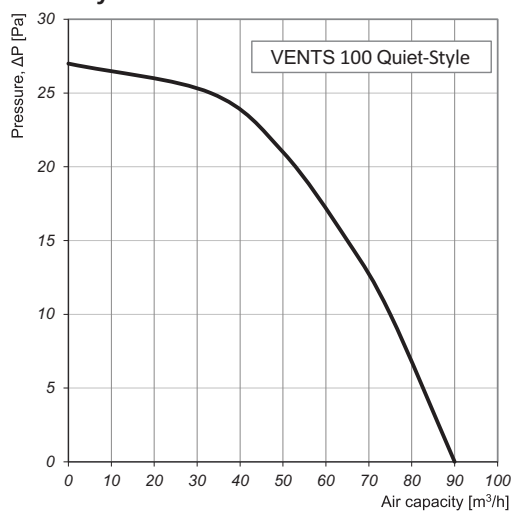

Overall dimensions

Model	Dimensions, mm			
	∅ D	□ B	L	L1
VENTS 100 Quiet-Style	99	200	130	49

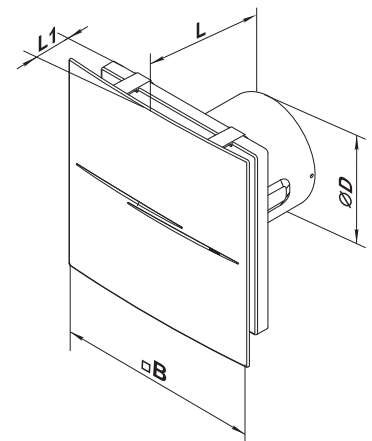

Certificates



The fans meet the applicable safety and electromagnetic compatibility standards.